

YCSE040-YCSE100 & YCRE040-YCRE100

ENGINEERING GUIDE

Revision 2

PC163-100 (0909)

WATER AND REMOTE AIR COOLED LIQUID CHILLERS WITH SCREW COMPRESSORS STYLE B (YCSE 134-320KW) (YCRE 127-307KW)

ASPAK

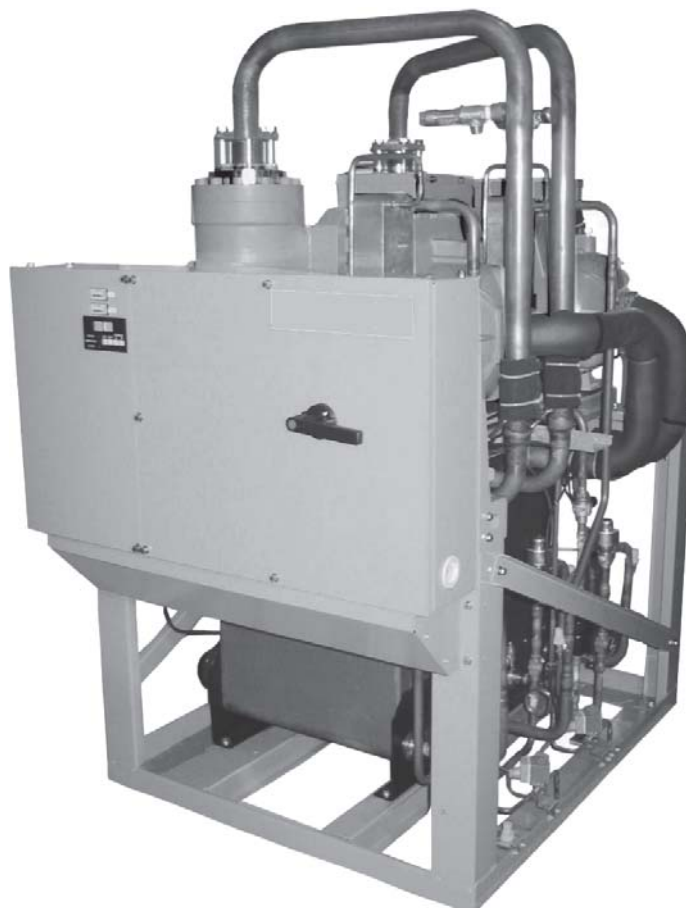

R407C

NOMINAL DATA

	YCSE					YCRE				
	040	050	060	080	100	040	050	060	080	100
Cooling Capacity (kW)*	134	160	194	232	320	127	153	190	254	307
Energy Efficiency Ratio (EER)	4.00	4.00	3.95	4.26	4.00	Not Applicable				
Efficiency Class	D	D	D	C	D					
ESEER	4.52	4.52	4.52	4.86	4.52					
Sound Pressure (EN 292-1991) (dB[A])	68	69	71	71	72	68	69	71	71	72

* At Eurovent Conditions

SPECIFICATION

YORK YCSE/YCRE R407C chillers are designed for water or water-glycol cooling. It is designed for indoor installation in a plant room. Units are available with one or two independent refrigerant circuits with a single evaporator and, on YCSE models, a single condenser. Units are completely factory assembled with all interconnecting refrigerant piping and wiring ready for field installation. The units are pressure tested, evacuated, and fully factory charged with refrigerant R407C and oil in each of the independent refrigerant circuits. After assembly, an operational test is performed with water flowing through the evaporator and condenser (YCSE) to ensure that each refrigerant circuit operates correctly.

YCSE/YCRE chillers are designed and built within an EN ISO 9001 accredited organisation and in conformity with the following European Directives:

- Machinery Directive (98/37/EC)
- Low Voltage Directive (2006/95/EC)
- EMC Directive (2004/108/EC)
- Pressure Equipment Directive (97/23/EC)
- Safety Code for Mechanical Refrigeration (EN378)

Compressors

The unit has suction cooled, semi-hermetic screw compressors. The compressors incorporate twin-screw rotors and solenoid valves for continuous capacity control. The compressors are equipped with a built-in oil separator, an oil sight glass, a crankcase oil heater and a suction filter. The compressors have a 2-pole motor with over current and thermostat protection. Start / Delta starting is provided as standard. All compressors are mounted on isolator pads to reduce transmission of vibration to the rest of the unit.

Refrigerant Circuits

Depending on model size, one or two independent refrigerant circuits are provided on each unit. Each circuit uses copper refrigerant pipe formed on computer controlled bending machines to reduce the number of brazed joints resulting in a reliable and leak resistant system.

Liquid line components include a service valve, a high absorption filter dryer, a sight glass with moisture indicator and an electronic expansion valve.

Suction line components include an optional service and isolation valve.

Discharge line components include a check valve, an optional service and isolation valve and a pressure relief valve.

Evaporator

The evaporator is a stainless steel brazed type plate heat exchanger. The waterside design working pressure is 10 barg. The refrigerant side design working pressure is 18 bar g. The cooler is thermally insulated with flexible closed cell foam. Water connection to the evaporator is via victaulic-grooved connections. Flange connections are available as an option.

Condenser (YCSE only)

The condenser is a stainless steel brazed type plate heat exchanger. The waterside design working pressure is 10 barg. The refrigerant side design working pressure is 30 bar g. Water connection to the condenser is via victaulic-grooved connections. Flange connections are available as an option.

Power and Control Panels

All power and controls are contained in an IP20 cabinet with hinged and gasket sealed outer doors.

The power section includes

A factory mounted non-fused disconnect switch with external handle to enable connection of the unit power supply. The disconnect switch can be used to isolate the power for servicing.

Factory mounted compressor contactors, fuses and over current relays to provide overload and short circuit protection.

The control section includes

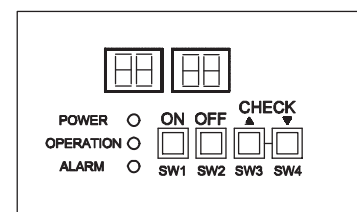

Four 7-segment LED display

Four push button switches

LED indicators for power, operation and alarm status

Customer terminal block for control inputs and liquid flow switch connection

Microprocessor boards to provide automatic operation and accurate temperature control.

Refrigerant Flow Diagram - YCSE 040, 050, 060, 100 Models

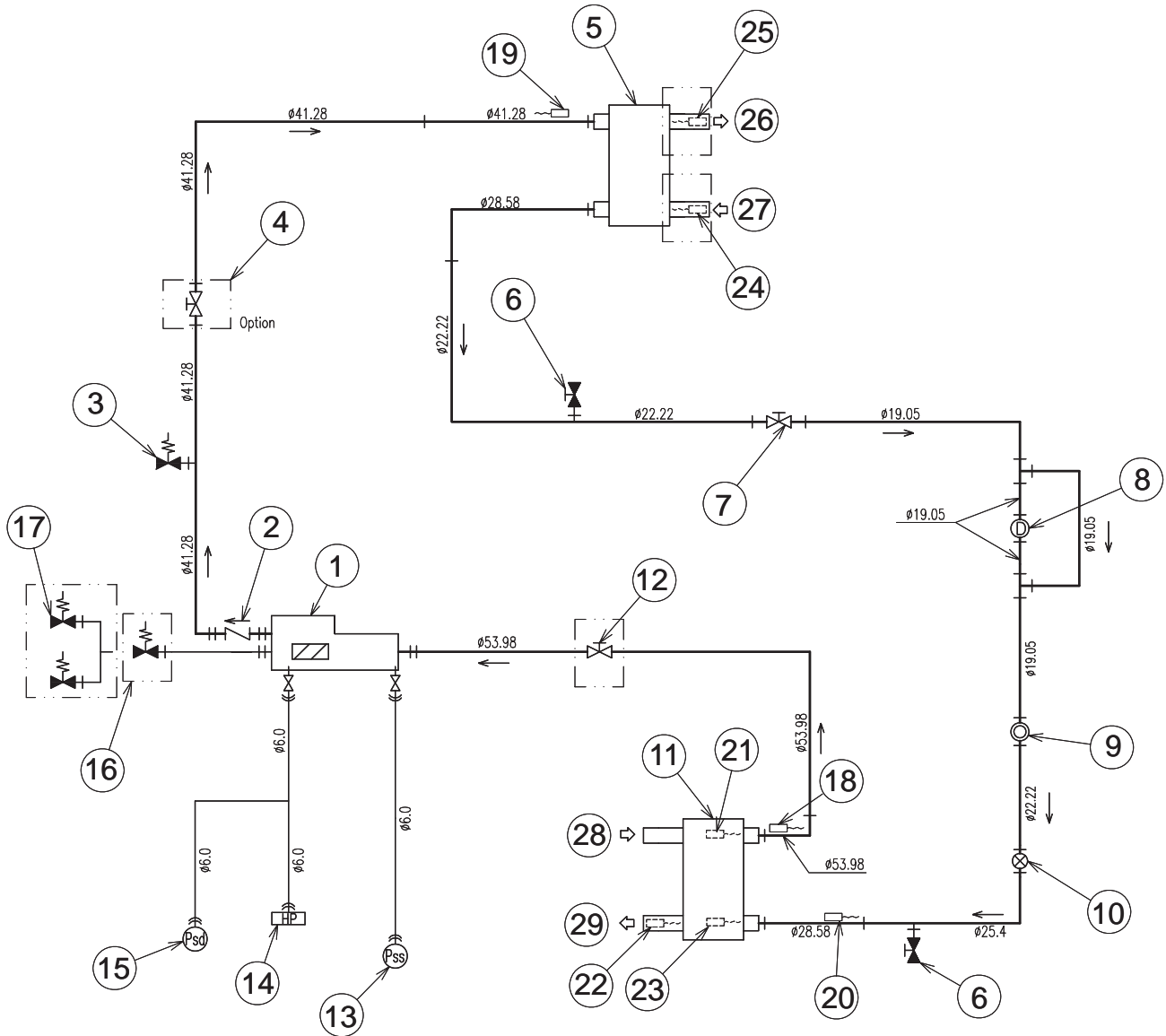

1	Compressor	16	Compressor Safety Valve (Option)
2	Check Valve	17	Compressor Dual Safety Valve (Option)
3	Pressure Relief Valve	18	Thermistor - Suction
4	Stop Valve (Option)	19	Thermistor - Discharge
5	Condenser	20	Thermistor - Evaporator
6	Stop Valve - Refrigerant Charge Point	21	Thermistor - Evaporator Water Inlet
7	Stop Valve	22	Thermistor - Evaporator Water Outlet
8	Drier	23	Thermistor - Evaporator Water Outlet
9	Sight Glass	24	Thermistor - Condenser Water Inlet (Option)
10	Electronic Expansion Valve	25	Thermistor - Condenser Water Outlet (Option)
11	Evaporator	26	Condenser Water Outlet
12	Stop Valve (Option)	27	Condenser Water Inlet
13	Low Pressure Sensor	28	Evaporator Water Inlet
14	High Pressure Switch	29	Evaporator Water Outlet
15	High Pressure Sensor		

ELECTRICAL CONNECTION

The following connection recommendations are intended to ensure safe and satisfactory operation of the unit. Failure to follow these recommendations could cause harm to persons, or damage to the unit, and may invalidate the warranty.

No additional controls (relays, etc.) should be mounted in the control panel. Power and control wiring not connected to the control panel should not be run through the control panel. If these precautions are not followed it could lead to a risk of electrocution. In addition, electrical noise could cause malfunctions or damage the unit and its controls.

Power Wiring

These units are suitable for 400 V, 3 phase plus neutral, 50 Hz supply only.

All electrical wiring should be carried out in accordance with local regulations. Route properly sized cables to the cable entries in the top of the power panel.

	Lug Size	Max. Cable Capacity (mm ²)
YCSE 040	M8	185
YCSE 050	M8	185
YCSE 060	M8	185
YCSE 080	M8	185
YCSE 100	M10	240
YCRE 040	M8	185
YCRE 050	M8	185
YCRE 060	M8	185
YCRE 080	M10	240
YCRE 100	M10	240

In accordance with EN 60204 it is the responsibility of the user to install over current protection devices between the supply conductors and the power supply terminals on the unit.

To ensure that no eddy currents are set up in the power panel, the cables forming each 3 phase power supply must enter via the same cable entry.

If separate entries for each cable forming the 3 phase supplies are used, the metal gland plate must be replaced by a non-metallic gland plate, with due regard given to sealing the panel to IP2X.

All sources of supply to the unit must be taken via a common point of isolation (not supplied by JCI).

Single Point Power Supply Wiring

All models require one field provided 400 V, 3Ø, + N 50 Hz + PE (Protected Earth) supply to the unit with circuit protection.

Connect the 3 phase supply to the non-fused disconnect switch located in the power panel.

Connect the earth wire to the main protective earth terminal located in the power panel.

CONNECTION DIAGRAM

YCSE

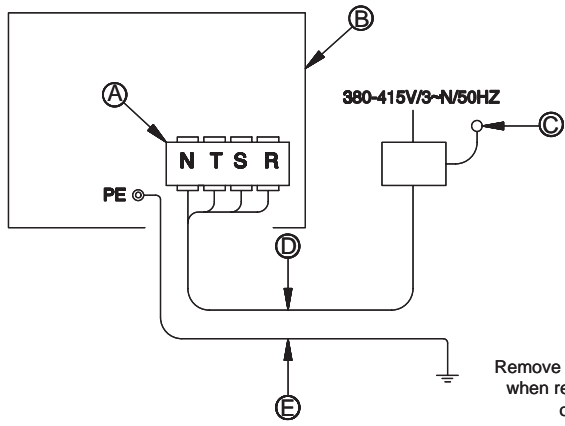

N°	Name
A	Main Power/Terminal Board (R,S,T,N)
B	Electrical Box
C	Main Power Switch
D	Main Power Wiring
E	Earth Wiring

The main connection to terminal N is required.

Remove link between 5 and 6 when remote control switch option is fitted

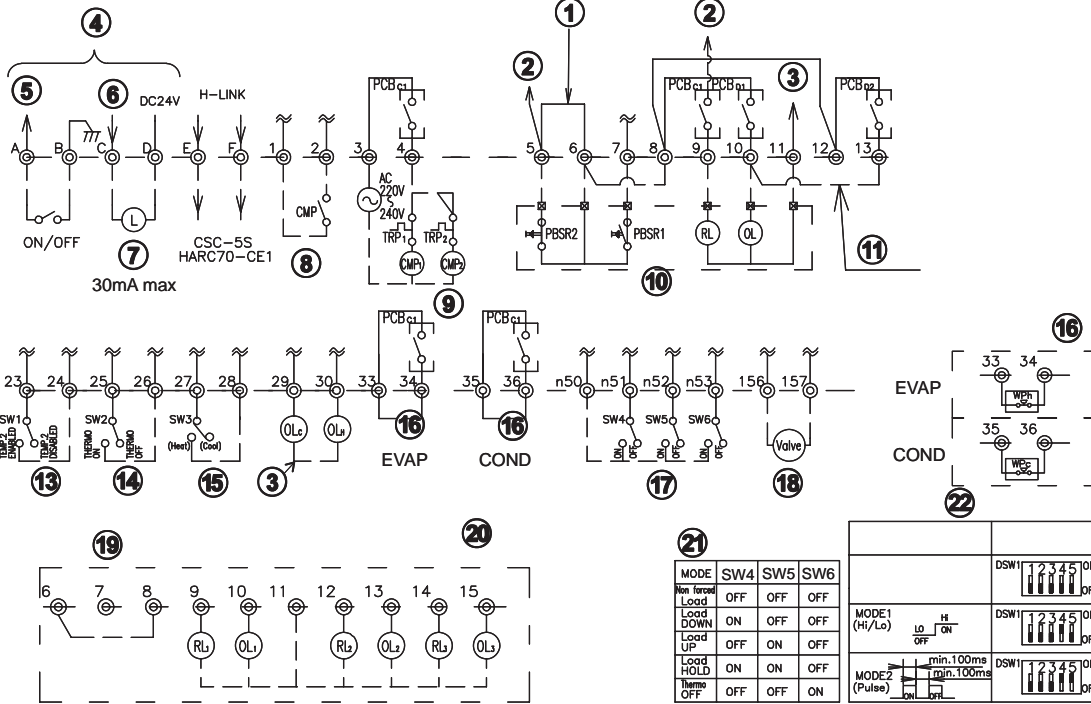

NOTES:

N°	Name
1	In case of remote control operation this wire shall be removed (using item 10).
2	R Phase
3	Neutral
4	Low Voltage / Remote Control
5	Run/Stop Signal
6	Alarm Signal
7	Alarm Lamp (30mA max)
8	Pump Interlock
9	Pump operation
10	Remote Control Switch (RSW-A) (OPTION)
11	2 Circuit Units
12	Not Fitted

N°	Name
13	2 nd. Setting Temperature
14	External Thermostat Operation
15	Operation Mode (OPTION)
16	Only used for: -Diff. Water Pressure switch (OPTION) -Flow Switch (OPTION)
17	Force Compressor Load Operation
18	Free Cooling Output signal (Only cycle N° 1)
19	In case of individual indication without Remote Control Switch
20	Customer wiring
21	Force compressor load
22	Setting of low voltage control

NOTE:

- All the setting shall be performed before Power ON.
- Remote / Local Change over Switch on Operation Switch shall be set, to Remote.
- Terminals 1 ~/21 are for AC220-240V, Terminals A ~/D are for DC24V. Terminals E ~/F are H-link (Low signal)

CHILLER SELECTION GUIDE - WATER

Data Required

To select a YORK YCSE/YCRE chiller the following information is required:

1. Design cooling capacity.
2. Chilled water entering and leaving temperatures.
3. Condenser water entering and leaving temperature.
4. Chilled water flow (l/s) if one of the temperatures in (2) is unknown.
5. Condenser water flow (l/s) if one of the temperatures in (3) is unknown.

Determine the capacity or water flow from:

- Cooling Capacity (kW) = Range (°C) x chilled water (l/s) x 4.18

Determine the heat rejection or water flow from:

- Heat Rejection (kW) = Range (°C) x condenser water (l/s) x 4.18

NOTE: If condenser coolant is glycol solution allow 2 K increase in condensing temperature to estimate the cooling capacity & power impact on your selection.

Chiller Selection Method

1. Determine the correct size of chiller by selecting the model which most closely matches the required capacity at the design conditions of leaving water temperature and condenser leaving water temperature.
2. Apply correction factors for fouling factor to the capacity and power values from the capacity tables. Ensure the corrected capacity is still sufficient for requirements.
3. Using the corrected capacity of the selected chiller adjust the design temperature range, or flow rate, to balance the formulae shown above.
4. Physical and electrical data can now be determined from the tables.
5. Always re-check that selections fall within the operating limitations.

YCSE Sample Selection

Confirm the system requirements

Cooling Capacity:	190 kW
Chilled Water Inlet Temperature:	12 °C
Chilled Water Outlet Temperature:	7 °C
Condenser Water Inlet Temperature:	30 °C
Condenser Water Outlet Temperature:	35 °C
Evaporator / Condenser Fouling Factors:	0.044 m ² /kW

Select Model and Read the Performance

From the capacity table, model YCSE060 can be selected with the following performance.

Cooling Capacity:	194 kW
Compressor Input Power:	49 kW
Heat Rejection	243 kW

Determine the Flow Rate

$$\begin{aligned} \text{Cooling Capacity (kW)} &= \text{Range (°C)} \times \text{chilled water (l/s)} \times 4.18 \\ &= \frac{194}{5 \times 4.18} = 9.3 \text{ l/s} \end{aligned}$$

$$\begin{aligned} \text{Heat Rejection (kW)} &= \text{Range (°C)} \times \text{condenser water (l/s)} \times 4.18 \\ &= \frac{243}{5 \times 4.18} = 11.6 \text{ l/s} \end{aligned}$$

Correct the Data

Fouling Factor

The cooling capacity and the compressor input should be corrected using the factors given below, if applicable. Recalculate flow rates as required.

Flow Rate

When the water Inlet/Outlet temperature difference is not 5°C, correct the flow rate by the following formula:

$$\text{Corrected Flow Rate} = \frac{5 \text{ (°C)} \times \text{Flow Rate}}{\text{Temp. Difference (°C)}}$$

The corrected Flow Rate must be confirmed to be within the working range.

Determine the Pressure Drops

Calculate the pressure drops using the graphs.

Evaporator pressure drop at a flow rate of 9.3 l/s would be 36.0 kPa.

Condenser pressure drop at a flow rate of 11.6 l/s would be 38.9 kPa.

Check the Data is within Limits

The data is within the unit operating limitations.

FOULING FACTORS

COOLER		
Fouling Factor m ² °C/kW	Capacity Factor	Comp. Input Factor
0.044	1.000	1.000
0.088	0.987	0.995
0.176	0.964	0.985
0.352	0.915	0.962

CONDENSER		
Fouling Factor m ² °C/kW	Capacity Factor	Comp. Input Factor
0.044	1.000	1.000
0.088	0.987	1.023
0.176	0.955	1.068
0.308	0.910	1.135

EVAPORATOR PRESSURE DROP GRAPH

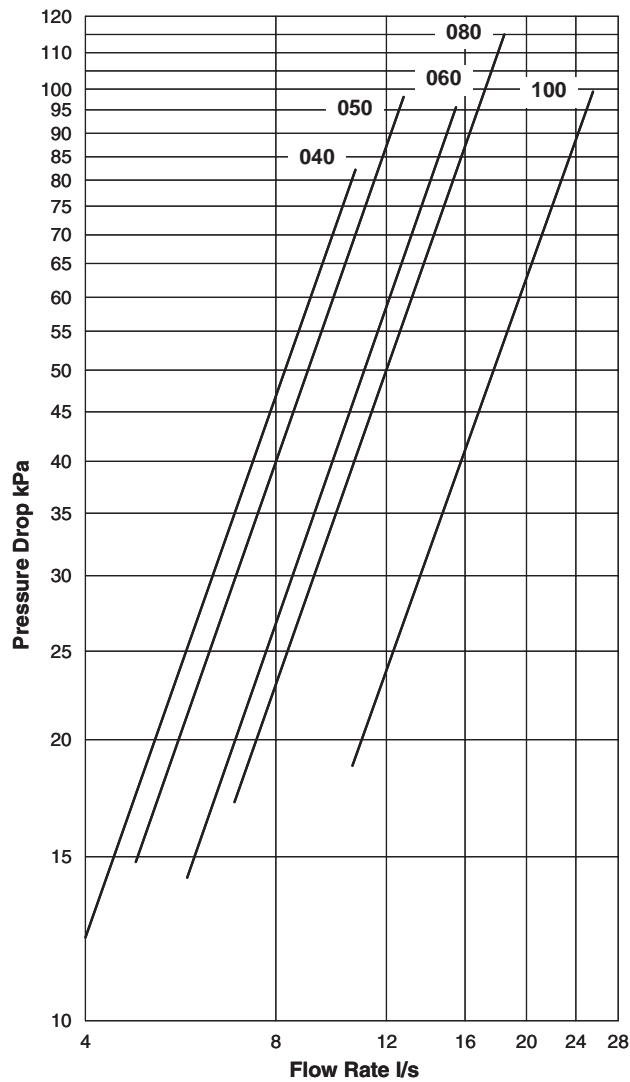

CONDENSER PRESSURE DROP GRAPH (YCSE ONLY)

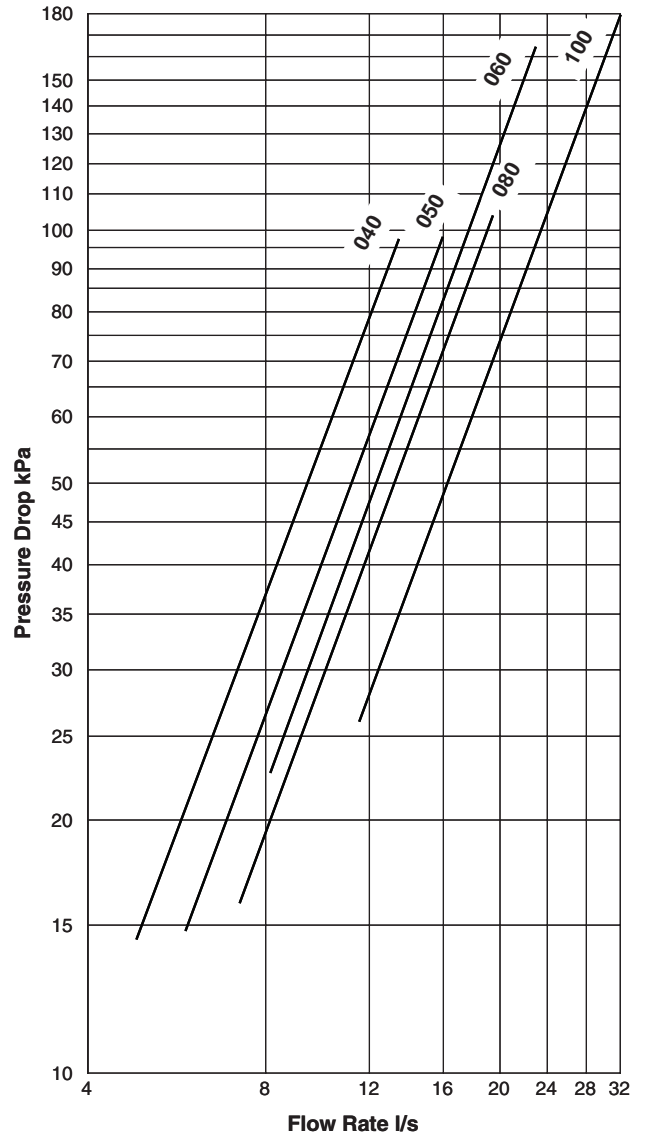

PRESSURE DROP FORMULAE

Models	Evaporator Pressure Drop (kPa)	Condenser Pressure Drop (kPa) (YCSE Only)
YCSE/YCRE040	$P = 0.8846 \times \text{Flow Rate (l/s)}^{1.912}$	$P = 0.7568 \times \text{Flow Rate (l/s)}^{1.872}$
YCSE/YCRE050	$P = 0.7503 \times \text{Flow Rate (l/s)}^{1.912}$	$P = 0.5341 \times \text{Flow Rate (l/s)}^{1.881}$
YCSE/YCRE060	$P = 0.506 \times \text{Flow Rate (l/s)}^{1.912}$	$P = 0.3725 \times \text{Flow Rate (l/s)}^{1.897}$
YCSE/YCRE080	$P = 0.433 \times \text{Flow Rate (l/s)}^{1.912}$	$P = 0.4145 \times \text{Flow Rate (l/s)}^{1.912}$
YCSE/YCRE100	$P = 0.2135 \times \text{Flow Rate (l/s)}^{1.897}$	$P = 0.2543 \times \text{Flow Rate (l/s)}^{1.893}$

OPERATING LIMITATIONS

Standard Models			YCSE040		YCSE050		YCSE060		YCSE080		YCSE100	
			Min.	Max.	Min.	Max.	Min.	Max.	Min.	Max.	Min.	Max.
Chilled Liquid	Liquid Outlet Temperature (Water)	°C	5 to 15 ⁽³⁾									
	Liquid Outlet Temperature (Glycol)	°C	-10 to 15 ⁽¹⁾⁽³⁾									
	Liquid Outlet Temperature Range	°C	4 to 8									
	Evaporator Flow Rate	l/s	4.0	10.7	4.8	12.8	5.8	15.5	6.9	18.5	10.6	25.5
	Evaporator Pressure Drop	kPa	12.3	82.2	14.8	98.2	14.3	95.5	17.2	114.6	18.8	99.4
	Maximum Water Side Pressure	bar	10									
Cooling Liquid	Liquid Outlet Temperature	°C	22 to 55*									
	Liquid Outlet Temperature Range	°C	2 to 10									
	Condenser Flow Rate	l/s	--	13.4	--	15.9	--	19.4	--	22.9	--	31.9
	Condenser Pressure Drop	kPa	--	97.0	--	97.7	--	103.2	--	164.5	--	178.8
	Maximum Water Side Pressure	bar	10									
Maximum Refrigerant Side Pressure	bar	30										
Power Supply Voltage 400V, 3 ~, 50 Hz (nominal)	V	360 to 440										
Recommended Minimum System Water Volume ⁽²⁾	litres	420		510		610		730		1010		
Minimum Ambient Air Temperature	°C	5										
Maximum Ambient Air Temperature	°C	46										

(1): Refer to Accessories and Options for further details

(2): Based on 2°C ON/OFF differential. System Volume should be increased if differential is lowered
The recommended volume ensures a minimum of 5 minutes cooling without interruption

(3): Minimum temperature is inclusive of control range.

Standard Models			YCRE040		YCRE050		YCRE060		YCRE080		YCRE100	
			Min.	Max.	Min.	Max.	Min.	Max.	Min.	Max.	Min.	Max.
Chilled Liquid	Liquid Outlet Temperature (Water)	°C	5 to 15 ⁽³⁾									
	Liquid Outlet Temperature (Glycol)	°C	-10 to 15 ⁽¹⁾⁽³⁾									
	Liquid Outlet Temperature Range	°C	4 to 8									
	Evaporator Flow Rate	l/s	4.3	9.6	5.2	11.6	6.4	14.3	8.6	19.1	10.4	23.1
	Evaporator Pressure Drop	kPa	14.4	66.9	17.6	81.5	17.6	82.0	12.7	57.5	18.2	82.5
	Maximum Water Side Pressure	bar	10									
Maximum Refrigerant Side Pressure	bar	30										
Power Supply Voltage 400V, 3 ~, 50 Hz (nominal)	V	360 to 440										
Recommended Minimum System Water Volume ⁽²⁾	litres	420		510		610		730		1010		
Minimum Ambient Air Temperature	°C	5										
Maximum Ambient Air Temperature	°C	46										

(1): Refer to Accessories and Options for further details

(2): Based on 2°C ON/OFF differential. System Volume should be increased if differential is lowered
The recommended volume ensures a minimum of 5 minutes cooling without interruption

(3): Minimum temperature is inclusive of control range.

YCSE	LCLT °C	Condenser Leaving Water Temperature °C																										
		22			25			30			35			40			45			50			55					
		Cool kW	Power kW	HR kW	Cool kW	Power kW	HR kW	Cool kW	Power kW	HR kW	Cool kW	Power kW	HR kW	Cool kW	Power kW	HR kW	Cool kW	Power kW	HR kW	Cool kW	Power kW	HR kW	Cool kW	Power kW	HR kW			
040	5	138	25	163	135	27	162	131	30	161	127	33	161	123	36	160	119	40	159	115	43	158	111	46	157			
	7	144	25	169	142	27	169	138	30	168	134	34	168	130	37	167	126	40	166	123	43	165	119	46	165			
	9	150	26	176	148	28	175	144	31	175	141	34	174	137	37	174	134	40	174	130	43	173	126	46	173			
	11	156	26	182	154	28	182	151	31	182	147	34	181	144	37	181	141	40	181	137	43	181	134	46	180			
	13	162	26	189	160	28	189	157	31	188	154	34	188	151	37	188	148	40	188	145	43	188	142	46	188			
	15	168	27	195	167	29	195	164	31	195	161	34	195	158	37	195	155	40	196	152	43	196	150	46	196			
050	5	165	30	194	162	32	194	157	36	193	152	40	192	147	44	191	142	47	190	137	51	189	133	55	187			
	7	172	30	202	169	32	202	165	36	201	160	40	200	155	44	199	151	48	198	146	51	198	142	55	197			
	9	179	31	210	177	33	209	172	37	209	168	40	208	164	44	208	160	48	207	155	51	207	151	55	206			
	11	186	31	217	184	33	217	180	37	217	176	41	217	172	44	216	168	48	216	164	51	216	160	55	215			
	13	194	32	225	191	34	225	188	37	225	184	41	225	180	44	225	177	48	225	173	52	225	169	55	225			
	15	201	32	233	199	34	233	196	38	233	192	41	233	189	45	233	185	48	233	182	52	234	179	55	234			
060	5	200	37	236	196	39	235	190	44	234	184	49	233	178	53	232	172	58	231	167	63	229	161	67	228			
	7	208	37	246	205	40	245	200	44	244	194	49	243	188	54	242	183	58	241	177	63	240	172	68	239			
	9	217	38	255	214	40	254	209	45	254	204	49	253	199	54	253	193	59	252	188	63	251	183	68	251			
	11	226	38	264	223	41	264	218	45	264	213	50	263	209	54	263	204	59	263	199	63	262	194	68	262			
	13	235	39	274	232	41	273	228	46	273	223	50	273	219	54	273	214	59	273	210	63	273	205	68	273			
	15	244	39	283	241	42	283	237	46	283	233	50	283	229	55	284	225	59	284	221	63	284	217	68	284			
080	5	239	41	279	234	44	278	227	49	276	220	54	274	213	59	273	206	65	271	199	70	269	192	75	267			
	7	249	41	290	245	44	290	239	49	288	232	55	287	225	60	285	219	65	283	212	70	282	206	75	280			
	9	260	42	302	256	45	301	250	50	300	244	55	299	237	60	297	231	65	296	225	70	295	219	75	294			
	11	270	42	313	267	45	312	261	50	311	255	55	311	250	60	310	244	65	309	238	70	308	232	75	307			
	13	281	43	324	278	46	323	272	51	323	267	56	323	262	60	322	256	65	322	251	70	321	246	75	321			
	15	291	44	335	288	46	335	284	51	335	279	56	335	274	61	335	269	66	334	264	70	334	259	75	334			
100	5	329	60	389	323	64	388	314	72	385	304	79	383	294	87	381	284	95	379	275	102	377	265	110	375			
	7	344	60	404	338	65	403	329	72	402	320	80	400	311	88	398	302	95	397	293	103	395	283	110	394			
	9	358	61	420	353	66	419	345	73	418	336	81	417	328	88	415	319	95	414	310	103	413	302	110	412			
	11	373	62	435	368	67	435	360	74	434	352	81	433	344	88	433	336	96	432	328	103	431	320	110	431			
	13	387	63	450	383	67	450	376	74	450	368	82	450	361	89	450	354	96	449	346	103	449	339	110	449			
	15	402	64	466	398	68	466	391	75	466	384	82	467	378	89	467	371	96	467	364	103	467	357	110	468			

LCLT: Leaving Chilled Liquid Temperature, Cool: Cooling Capacity, Power: Compressor Power Input, HR: Heat Rejection

YCSE	LCLT °C	Condenser Leaving Water Temperature °C																				
		25			30			35			40			45			50			55		
		Cool kW	Power kW	HR kW	Cool kW	Power kW	HR kW	Cool kW	Power kW	HR kW	Cool kW	Power kW	HR kW	Cool kW	Power kW	HR kW	Cool kW	Power kW	HR kW	Cool kW	Power kW	HR kW
040	4	127	26	154	123	29	153	120	33	152	116	35	151	110	39	149	106	42	148	102	45	148
	2	121	26	147	117	29	146	113	32	145	108	35	143	104	39	143	100	42	142	96	45	141
	0	116	26	141	110	29	139	106	32	139	101	35	136	97	38	136	92	42	134	88	45	133
	-2	110	25	135	106	29	135	101	32	133	95	36	131	91	39	130	86	42	128			
	-4	105	25	130	99	28	128	94	32	126	88	35	124	84	39	123	79	42	121			
	-6	99	25	124	95	28	124	90	32	122	84	35	119	79	39	117						
	-8	94	24	118	88	28	116	83	31	114	77	35	112	72	38	110						
	-10	88	24	112	82	28	109	76	31	107	70	35	105	64	38	102						
050	4	152	31	183	147	35	182	143	39	182	138	42	180	132	46	178	127	50	177	122	54	176
	2	144	31	175	140	35	174	135	38	173	129	42	171	124	46	170	119	50	169	115	54	168
	0	138	30	169	132	34	166	127	38	165	121	42	163	116	46	162	110	50	160	105	54	159
	-2	131	30	162	126	34	161	120	38	158	114	42	156	109	46	155	102	50	153			
	-4	125	30	155	118	34	152	112	38	150	106	42	148	101	46	147	94	50	145			
	-6	119	29	148	114	34	148	107	38	145	101	42	143	94	46	140						
	-8	112	29	141	106	34	139	99	38	137	92	42	134	86	46	131						
	-10	106	29	134	97	33	130	91	38	128	84	42	126	76	46	122						
060	4	184	38	223	179	43	222	173	48	221	167	52	219	160	57	217	154	61	215	148	66	214
	2	175	38	213	169	43	212	164	47	211	156	52	208	150	57	207	145	61	206	139	66	205
	0	167	37	205	160	42	202	154	47	201	146	52	198	141	56	197	133	61	194	127	66	194
	-2	159	37	196	153	42	195	146	47	193	138	52	190	132	57	189	124	62	186			
	-4	151	37	188	144	42	185	136	47	182	128	52	180	122	56	179	114	62	176			
	-6	144	36	180	138	42	180	130	47	177	122	52	174	114	57	171						
	-8	136	36	172	128	41	169	120	46	166	112	51	163	104	56	160						
	-10	128	35	163	118	41	159	110	46	156	102	51	153	92	56	148						
080	4	221	43	263	214	47	261	207	53	260	200	58	258	191	63	254	184	68	252	177	73	251
	2	209	42	251	202	47	250	196	52	248	187	58	244	180	63	243	173	68	241	166	73	239
	0	200	42	242	191	47	238	184	52	237	175	57	232	168	63	231	159	68	227	152	73	226
	-2	190	41	232	183	47	230	174	52	226	165	58	222	158	63	221	148	69	217			
	-4	181	41	222	172	46	218	162	52	214	153	57	210	146	63	209	137	69	206			
	-6	172	40	212	165	46	211	155	52	207	146	57	203	136	63	199						
	-8	163	40	202	153	46	199	144	51	195	134	57	191	124	62	187						
	-10	153	39	192	141	45	186	132	51	183	122	57	179	110	62	172						
100	4	304	63	367	295	70	365	285	78	363	276	85	361	264	93	356	254	100	354	245	108	352
	2	289	62	350	279	70	349	270	77	347	257	85	342	248	93	341	238	100	338	229	108	337
	0	276	61	337	264	69	332	254	77	331	242	84	326	232	92	324	220	100	319	210	108	318
	-2	262	61	323	253	69	322	240	77	317	227	85	312	218	93	310	205	101	306			
	-4	250	60	310	237	68	305	224	76	300	211	84	295	202	92	294	189	101	290			
	-6	238	59	297	228	68	296	214	76	290	201	84	285	188	92	280						
	-8	224	58	283	211	67	278	198	75	273	185	83	268	172	91	263						
	-10	211	57	269	195	66	261	181	75	257	168	83	251	152	91	243						

Values given for 30% Ethylene Glycol. LCLT: Leaving Chilled Liquid Temperature, Cool: Cooling Capacity, Power: Compressor Power Input, HR: Heat Rejection

ESEER DATA YCSE MODELS

YCSE 040					
Load (%)	Condenser Water Entering Temp. (°C)	Cooling Capacity (kW)	Input Power (kW)	EER	ESEER
100	30	134.0	33.5	4.00	4.52
75	26	100.5	22.7	4.43	
50	22	67.0	13.7	4.88	
25	18	33.5	8.2	4.09	

YCSE 050					
Load (%)	Condenser Water Entering Temp. (°C)	Cooling Capacity (kW)	Input Power (kW)	EER	ESEER
100	30	160.0	40.0	4.00	4.52
75	26	120.0	27.1	4.43	
50	22	80.0	16.4	4.88	
25	18	40.0	9.8	4.09	

YCSE 060					
Load (%)	Condenser Water Entering Temp. (°C)	Cooling Capacity (kW)	Input Power (kW)	EER	ESEER
100	30	194.0	49.1	3.95	4.52
75	26	145.5	32.8	4.43	
50	22	97.0	19.9	4.88	
25	18	48.5	11.8	4.09	

YCSE 080					
Load (%)	Condenser Water Entering Temp. (°C)	Cooling Capacity (kW)	Input Power (kW)	EER	ESEER
100	30	232.0	54.5	4.26	4.52
75	26	174.0	37.3	4.67	
50	22	116.0	22.1	5.25	
25	18	58.0	12.7	4.55	

YCSE 100					
Load (%)	Condenser Water Entering Temp. (°C)	Cooling Capacity (kW)	Input Power (kW)	EER	ESEER
100	30	320.0	80.0	4.00	4.52
75	26	240.0	54.2	4.43	
50	22	160.0	32.8	4.88	
25	18	80.0	19.5	4.09	

Data at 7°C Leaving Chilled Water Temperature with constant flow rates
 Flow Rates are set at 12/7°C Chilled Water Temperatures and 30/35°C Cooling Water Temperatures

PHYSICAL DATA - YCSE MODELS

Standard Models YCSE			040	050	060	080	100
Number of refrigerant circuits			1				2
Refrigerant Charge	Circuit 1 (/ Circuit 2)	kg	12	14	16	18	14 / 14
Oil Charge	Circuit 1 (/ Circuit 2)	litre	6	6	6	6	6/6
Compressor	Number of Compressors		1				2
	Type		Semi-hermetic Screw				
	Capacity Control	%	15-100				7.5,15-100
Evaporator	Number of Evaporator		1				
	Type		Braze PHE				
	Water Volume	litre	13.7	15.2	19.5	19.5	40.8
	Water Connections	Inch	3	3	3	3	3
Condenser	Number of Condenser		1				
	Type		Braze PHE				
	Water Volume	litre	13.5	16.9	21.7	25.0	34.1
	Water Connections	Inch	3	3	3	3	3
Dimensions	Length	mm	850	850	850	850	1465
	Width	mm	1105	1105	1105	1105	1105
	Height	mm	1520	1520	1520	1520	1700
Weight	Shipping Weight	kg	750	765	830	950	1570
	Operating Weight	kg	780	800	875	1000	1655

PHYSICAL DATA - YCRE MODELS

Standard Models YCRE			040	050	060	080	100
Number of refrigerant circuits			1				2
Refrigerant Charge	Circuit 1 (/ Circuit 2) ⁽¹⁾	kg	12	14	16	18	14 / 14
Oil Charge	Circuit 1 (/ Circuit 2) ⁽²⁾	litre	6	6	6	6	6/6
Compressor	Number of Compressors		1			2	
	Type		Semi-hermetic Screw				
	Capacity Control	%	15-100			7.5,15-100	
Evaporator	Number of Evaporator		1				
	Type		Braze PHE				
	Water Volume	litre	13.7	15.2	19.5	32.4	40.8
	Water Connections	Inch	3	3	3	3	3
Connection Sizes	Discharge Line	Inch	1 5/8	1 5/8	1 5/8	1 5/8	1 5/8
	Liquid Line	Inch	1 1/8	1 1/8	1 1/8	1 1/8	1 1/8
Dimensions	Length	mm	885	885	885	1471	1471
	Width	mm	1045	1045	1104	1104	1104
	Height	mm	1562	1562	1562	1720	1720
Weight	Shipping Weight	kg	630	680	730	1200	1310
	Operating Weight	kg	650	710	760	1250	1370

(1): Refrigerant charge should be adjusted according to the requirements of the interconnecting refrigerant pipe runs and condenser selection (specific to each application).

(2): Additional oil may be required when commissioning dependant on the interconnecting refrigerant pipe runs and condenser selection (specific to each application).

ELECTRICAL DATA - YCSE MODELS

YCSE	Nominal Running Conditions		Maximum Running Conditions	Start up Amps ⁽³⁾
	kW	Amps ⁽¹⁾ at 400 V	Amps ⁽²⁾ at 400V	
040	34	55	69	121
050	40	66	82	155
060	49	80	101	188
080	55	89	112	140
100	80	131	164	178

(1) Nominal Running Amps at 7°C Leaving Evaporator Liquid Temperature and 35°C Leaving Condenser Liquid Temperature

(2) Maximum Running Amps is the maximum unit running current under the following conditions:
Supply voltage: 90% of rated voltage; Unit capacity: 100% at maximum operating conditions.

(3) Unit maximum starting current , when last compressor starts.

ELECTRICAL DATA - YCRE MODELS

YCRE	Nominal Running Conditions		Maximum Running Conditions	Start up Amps ⁽³⁾
	kW	Amps ⁽¹⁾ at 400 V	Amps ⁽²⁾ at 400V	
040	34	59	77	125
050	42	73	95	161
060	52	87	115	195
080	68	117	154	144
100	84	145	190	184

(1) Nominal Running Amps at 7°C Leaving Evaporator Liquid Temperature and 45°C Condenser Saturation Temperature

(2) Maximum Running Amps is the maximum unit running current under the following conditions:
Supply voltage: 90% of rated voltage; Unit capacity: 100% at maximum operating conditions.

(3) Unit maximum starting current , when last compressor starts.



www.johnsoncontrols.com